

## Product Highlights

### Easy transport

★The unique rear mast slide and lightweight design make this model easy to load into a light truck. Outrigger storage, wide forklift handling slots, transport fixing holes and crane lifting lug holes increase the convenience of transportation.

### Sturdy mast and platform

★The sturdy aviation aluminum profile mast provides users with comfort and safety at any height.

### Doorway passing ability and flexible maneuverability

★This series of models (except AMP40) can easily pass through standard doorways without tilting.

### Closer working distance

★The compact X-shaped foot point allows the machine to get closer to the wall, so that the operator is only an arm's length away from the work point.



## Standard Features

Aluminum platform basket	Lower beeper warning
Polyurethane non-mark tyres	Tilt device (only for AMP40)
Leverage ro-ro device	Maintenance-free Battery
Lifting ears	Emergency Lower Down
Two controls: platform control and ground control	Outrigger storage frame

## Options Features

Door type standard/ narrow platform	Tool box
Fiber glass platform	Top limit protection auto-stop device
DC power	Working Flashing Light
Staircase bracket	Equipment protection cover



**AMP SERIES**  
**AMP-20**  
PORTABLE TYPE AERIAL WORK PLATFORM

Model	AMP20	
Dimension	Metric	Imperial
Max. Working Height m H1	8m	26ft 3in
Max. Platform Height m H2	6m	19ft 8in
Lift capacity kg	159kg	350.53 lb
Basket size (B*C) m	0.69m×0.68m	2ft3in×2ft3in
Stowed size (E*F*D) m	1.27m×0.78m×1.97m	4ft2in×2ft7in×6ft6in
Height, tilted back (M) m	—	—
Length, tilted back (J) m	—	—
Outrigger footprint (I*K) m	1.77m×1.49m	5ft10in×4ft11in
Wall access front/side m H*G	0.18m/0.45m	7in/18in
Power (AC/DC)	220V/110V/12V	220V/110V/12V
Weight (AC/DC) kg	355kg/405kg	783lb/893lb

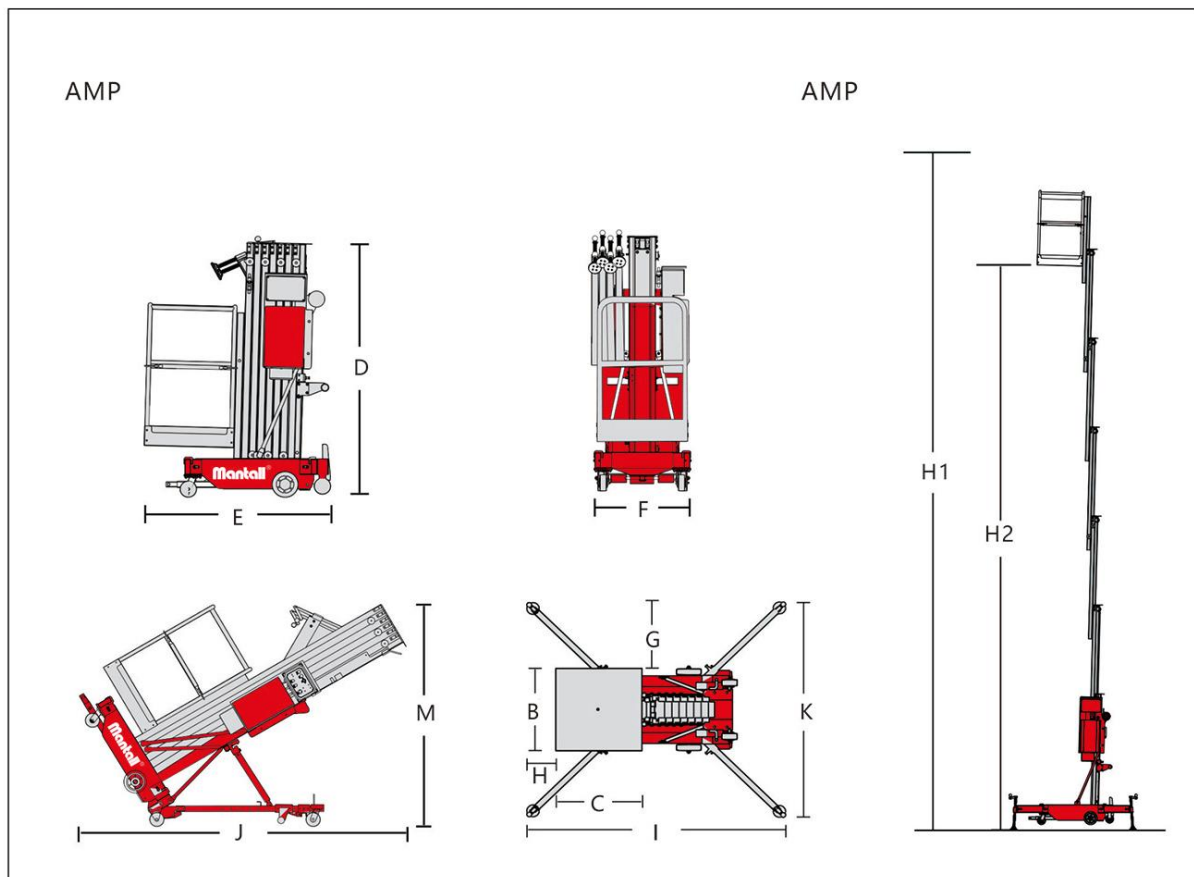

The images in this manual are for illustration only, and all copyrights belong to our company. Due to continuous technological updates, product parameters may change without prior notice.



Mantall AMP-20

严禁站人  
UNDER THE BOOM

HDL5330THB 4653D

HDL5380THB

Mantall  
AMP-20  
www.mantall.com